

MCEP

DISTRIBUTION



Catalog and Prices 2024

Drilling | Blasting | Ground engaging tools | Powerwashers | Specific products





Société par actions simplifiées (SAS) with a capital of 30 000 € - RCS BESANCON B 807 572 326



MCEP DISTRIBUTION – 3 rue du Prélot
25340 L'HOPITAL SAINT-LIEFFROY - FRANCE



www.mcep-distribution.com



Commercial :	commercial@mcep-distribution.com	+33 7 71 24 21 58
Technical :	eric.petit@mcep-distribution.com	+33 6 26 49 69 20
Administration :	admin@mcep-distribution.com	+33 6 48 00 66 08





Drilling

Top hammer tools	p. 4
Down the hole tools	p. 6
Accessories and equipment	p. 8



Blasting

Measuring and firing equipment	p. 10
Loading accessories	p. 12
Blasting mats	p. 14
ANFO mixers	p. 16



Ground engaging tools - Wear material

Teeth and adapters	p. 18
Edges and blades / Reinforcements	p. 20
Custom parts	p. 22
Points and picks	p. 24



Powerwashers

Portable and mobile powerwashers	p. 26
Autonomous powerwashers	p. 28
Accessories	p. 30



Specific products

Self-drilling systems	p. 32
Drill hammers and integral steels / Spare parts	p. 34

Product catalogs available on request.

Prices ex warehouse / partner factory, exclusive of all taxes.

Transport prices: Please consult us.

Other products: Please contact us.

Availability: To be confirmed at time of order, subject to stock availability.

Validity: 31/12/2024, except in the event of major changes in economic data.





Drilling

Top hammer tools



We offer bits, shanks and coupling sleeves from R22 to GT60, as well as shanks for the majority of top-hammers on the market: Epiroc, Sandvik, Furukawa, etc.

Below is a non-exhaustive list and prices from T38 to GT60. Please consult us for any other product.

Drop Center Bit		Flat Face Bit		Rods and coupling sleeves	
-----------------	--	---------------	--	---------------------------	--

T38					
Regular skirt 76 mm	101,51 €	Regular skirt 76 mm	108,26 €	MM 3050 mm	210,12 €
Regular skirt 89 mm	130,71 €	Regular skirt 89 mm	138,92 €	MM 3660 mm	252,76 €
Retrac skirt 76 mm	118,96 €	Retrac skirt 76 mm	131,61 €	MF 3050 mm	268,52 €
Retrac skirt 89 mm	149,40 €	Retrac skirt 89 mm	168,95 €	MF 3660 mm	315,34 €
				Sleeve 180 mm	47,66 €

T45					
Regular skirt 76 mm	105,12 €	Regular skirt 76 mm	112,77 €	MM 3050 mm	284,28 €
Regular skirt 89 mm	132,30 €	Regular skirt 89 mm	141,21 €	MM 3660 mm	333,72 €
Regular skirt 102 mm	180,41 €	Regular skirt 102 mm	198,49 €	MM 4265 mm	383,16 €
Retrac skirt 76 mm	114,44 €	Retrac skirt 76 mm	133,25 €	MF 3050 mm	356,64 €
Retrac skirt 89 mm	154,14 €	Retrac skirt 89 mm	171,45 €	MF 3660 mm	411,72 €
Retrac skirt 102 mm	218,03 €	Retrac skirt 102 mm	230,89 €	MF 4265 mm	466,80 €
				Sleeve 180 mm	56,63 €

T51					
Regular skirt 89 mm	142,18 €	Regular skirt 89 mm	150,09 €	MM 3660 mm	420,24 €
Regular skirt 102 mm	185,77 €	Regular skirt 102 mm	198,52 €	MF 3660 mm	516,38 €
Regular skirt 115 mm	226,79 €	Regular skirt 115 mm	248,14 €	MF 4265 mm	585,23 €
Retrac skirt 89 mm	164,08 €	Retrac skirt 89 mm	174,46 €	Sleeve 210 mm	66,96 €
Retrac skirt 102 mm	119,98 €	Retrac skirt 102 mm	232,51 €		
Retrac skirt 115 mm	260,86 €	Retrac skirt 115 mm	279,73 €		

GT60					
Regular skirt 102 mm	221,09 €	Regular skirt 102 mm	238,19 €	MM 3660 mm	703,28 €
Regular skirt 115 mm	270,66 €	Regular skirt 115 mm	297,77 €	MF 3660 mm	852,36 €
Regular skirt 127 mm	333,86 €	Regular skirt 127 mm	360,76 €	MF 4265 mm	934,98 €
Retrac skirt 102 mm	263,43 €	Retrac skirt 102 mm	278,24 €	MF 4915 mm	1 017,60 €
Retrac skirt 115 mm	311,27 €	Retrac skirt 115 mm	335,38 €	Sleeve 320 mm	125,08 €
Retrac skirt 127 mm	392,47 €	Retrac skirt 127 mm	433,07 €		





Drilling

Down the hole tools



We offer 3.5", 4", 5" and 6" hammers, with cutters from 90 mm to 219 mm for these hammers and associated drill pipes.

Below is a non-exhaustive list and price list. Please consult us for any other product.

Hammer	
GON350 - 3,5"	1 325,00 €
GON400 - 4"	1 437,50 €
GON500 - 5"	2 362,50 €
GON600 - 6"	3 062,50 €

Flat Face Bit	
90 mm	242,40 €
95 mm	259,20 €
100 mm	274,80 €
105 mm	285,60 €
110 mm	314,40 €
115 mm	333,60 €
127 mm	369,60 €
130 mm	382,80 €
140 mm	502,80 €
152 mm	541,20 €
165 mm	598,80 €
171 mm	639,60 €
190 mm	838,80 €
203 mm	918,00 €
219 mm	1177,20 €

Drill Pipe 5 m	
d. 76 mm th. 6,3 mm	358,80 €
d. 89 mm th. 6,3 mm	478,80 €
d. 114 mm th. 8,8 mm	630,00 €





Drilling

Accessories and equipment



Drilling grease:

We offer drilling grease TI-FOR-4100, charged with zinc for improved friction resistance. It is packaged in 5 kg buckets, complete box of 4 buckets.



Grease TI-FOR-4100 10,69 € / kg
Indicative price subject to change depending on oil prices

Drilling attachments:

Our partner in Finland can offer you a range of hydraulic drilling attachments to be assembled on hydraulic excavators, controlled from the excavator cab (AutoDrill system). Please contact us for further information on technical characteristics and prices.

Model	Characteristics		
Excadrill 22A	920 kg	For excavator 9 to 21 t	Drilling diameter 30 to 41 mm in R22
Excadrill 25A	950 kg	For excavator 10 to 21 t	Drilling diameter 30 to 45 mm in R25
Excadrill 28A	1000 kg	For excavator 13 to 21 t	Drilling diameter 38 to 51 mm in R28
Excadrill 38A	2500 kg	For excavator 21 to 35 t	Drilling diameter 45 to 76 mm in T38
Excadrill 45A	2600 kg	For excavator 25 to 40 t	Drilling diameter 51 to 89 mm in T45
Excadrill 51A	2850 kg	For excavator 35 to 45 t	Drilling diameter 64 to 127 mm in T51

Pneumatic and hydraulic drill rigs:

Our partner in Brazil can offer you one model of pneumatic drill rig and three models of hydraulic drill rigs equipped with top-hammers. The pneumatic drill can also be fitted down the hole. Please contact us for further information on technical characteristics and prices.

Model	Characteristics
MW 5000	Pneumatic – Drilling diameter 51 to 89 mm in R32, T38 or T45
FOX 8-20	Hydraulic without cabin – Drilling diameter 64 to 89 mm in T38 or T45
FOX 8-30	Hydraulic with cabin – Drilling diameter 64 to 89 mm in T38 or T45
FOX 12-30	Hydraulic with cabin – Drilling diameter 64 to 102 mm in T38 or T45

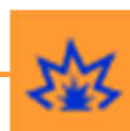



Blasting

Measuring and firing equipment



Our blasting equipment includes loading equipment (pump for dewatering blast holes), firing equipment (electric exploders, ohmmeter), measuring equipment (vibrographs) and safety equipment (blasting alarm, lightning detectors, etc.).

Please contact us for any other product.

Dewatering pumps	
Pump 3/4"	3 328,00 €
Sleeve 63-76 mm	205,70 €
Sleeve 70-88 mm	205,70 €
Sleeve 88-108 mm	205,70 €
Pump 1"	3 599,00 €
Sleeve 88-108 mm	252,40 €
Sleeve 102-121 mm	252,40 €
Sleeve 121-146 mm	261,75 €
Sleeve 149-172 mm	271,10 €

Firing equipment	
Exploder AI-1200 110 μ F	2 050,00 €
Exploder AI-2600 70 μ F	2 980,00 €
Exploder AI-2600 140 μ F	4 630,00 €
Exploder AI-2600 210 μ F	5 425,00 €
Digital ohmmeter OD-3	509,00 €



Measuring equipment	
Vibrograph Tellus 4 channels	5 810,00 €
Vibrograph Tellus 7 channels	7 730,00 €
Vibrograph Gaia 3 channels	4 215,00 €
Vibrograph Gaia 4 channels	4 725,00 €

Safety equipment	
Lightning detectors	
Detector STRIKE ALERT HD	399,00 €
Detector STORM PRO II	1 029,00 €
Transport case STORM PRO II	103,00 €
Blasting alarm	
Rechargeable battery alarm	350,00 €
Spare transport case	66,00 €
Car socket	43,50 €





Blasting

Loading accessories



Our range of blasting accessories is wide, and includes stemming rods, cartridge extractors, wire to connect the blast to the exploder, liner for ANFO, multimeters to check the depth of drilling, etc.

Below is a non-exhaustive list with prices. Please contact us for any other product.



Blasting accessories	
Stemming rod d. 27 mm l. 2 m	63,15 €
Stemming rod d. 40 mm l. 2 m	88,20 €
Cartridge extractor in brass for stemming rod 33/40	140,40 €
Weight in brass 6 kg l. 300 mm d. 55 mm	130,40 €
Cord d. 8 mm l. 30 m	28,35 €
Firing line 2x113/100°, 100 m spool	92,00 €
Connecting wire 2x51/100°, 500 m spool	142,00 €
Wire reel d. 380 mm, for 400 m wire	214,50 €
Liner diameter 70 mm th. 150 μ, 100 m spool	36,30 €
Liner diameter 80 mm th. 150 μ, 100 m spool	40,50 €
Aluminum funnel for ANFO 560/70 mm	246,00 €
Shutter 64/130 mm – Box of 75 pcs	5,80 €
Multimeter 30 m – reel, tape and weight	102,00 €
Tape 30 m and weight for multimeter	77,10 €
Tape 30 m for multimeter	53,65 €
Reel for multimeter	25,15 €
Crimping pliers	105,80 €
Shotfirer knife	13,70 €





Blasting

Blasting mats



Blasting mats are used to prevent projections during blasting with nearby constructions. We offer three different models:

MODEL XL – Standard mat sewn with 12 mm cables and reinforced with additional cable at the ends. Single 22mm cable handling loop.

MONSTER – Same with reinforced handling loop 22 mm double cable.

HANDMAT – For small blasts, manual handling, weight 55 to 95 kg.

All our models are assembled with a patented sewing pattern, allowing increased strength and multiple reuses.

Our blasting mats are made with the most wear-resistant parts of recycled truck tires. They are designed specifically for blasting, with no exposed cable ends that could cut wires, tubes or cords on the surface, or injure operators.

Below is the price for our standard dimensions, ex works from our partner in Poland. Other dimensions manufactured on demand.

MODEL XL		
6 x 3,20 m	1 300 kg	711,00 €
5 x 3,00 m	1 100 kg	613,00 €
4 x 3,00 m	850 kg	541,00 €
3 x 3,00 m	650 kg	474,00 €
2 x 3,00 m	450 kg	433,00 €



MONSTER		
6 x 3,20 m	1 300 kg	768,00 €
5 x 3,00 m	1 100 kg	670,00 €
4 x 3,00 m	850 kg	598,00 €



HANDMAT		
1 x 1,55 m	95 kg	155,00 €
1 x 1,25 m	75 kg	129,00 €
1 x 0,90 m	55 kg	98,00 €





Blasting

ANFO mixers

When local regulations allow it, the ANFO mixer is an interesting alternative for on-site manufacturing. Our units are offered on standard chassis, skid or wheel (index F, S or W), with electric, pneumatic or hydraulic power (index E, A or H), depending on model.

Note: Product reserved for export and subject to provision of authorization for use.

Indicative price ex works from South Africa, variable depending on the EUR/ZAR exchange rate.



ANFO mixers

30SE - 30 kg/min electric	8 185,00 €
50SA – 50 kg/min pneumatic	8 735,00 €
50SH – 50 kg/min hydraulic	8 735,00 €
50FE – 50 kg/min electric	8 560,00 €
50FH – 50 kg/min hydraulic	8 735,00 €
50WE – 50 kg/min electric	8 735,00 €
50WA – 50 kg/min pneumatic	8 870,00 €
50WH – 50 kg/min hydraulic	8 870,00 €
200WA – 200 kg/min pneumatic	15 890,00 €
200TH – 200 kg/min hydraulic, skid frame for truck with side delivery	16 660,00 €
200FE – 100/200 kg/min electric, with variable gear	16 980,00 €
MB120 – Fixed station with bagging hopper, 120 kg/min electric	24 680,00 €





Ground engaging tools - Wear material

Teeth and adapters



We offer a complete range of teeth and adapters that can be fitted to most manufacturers on the market: Caterpillar, Esco, Komatsu, CNH, MTG, Volvo, etc.

Tell us the O.E.M. (Original Equipment Manufacturer) reference you are looking for, and we will send you our best price quote.

Some examples of the tools we offer (full catalog available on request) :

CATERPILLAR			
Horizontal fixing Standard and Hammerless	Serie XTREM:	<ul style="list-style-type: none"> • RC Rock Chisel • AH Abrasion Heavy • LS Long Symmetric 	<ul style="list-style-type: none"> • GD General Duty • PL Penetration Long • SP Standard Penetration
	Serie ETE:	<ul style="list-style-type: none"> • Short • Long Side Nerve • Long Central Nerve • Rock Penetration 	<ul style="list-style-type: none"> • Abrasion • Penetration • Long Heavy Duty • Tiger / Twin Tiger
Vertical fixing 14, 15 et 20	System K :	<ul style="list-style-type: none"> • Penetration Plus • GD General Duty • TL Tiger Long • AR Abrasion 	Ripper: D3 to D11 End bits
One-piece tooth			

CNH		
Fiat	New Holland	Case

VOLVO
GPE General Purpose AMRL Abrasion Heavy Duty



ESCO
Conical system Helilok system Drilling Super V size 13 to 39 Ripper size 22, 25, 35, 39

KOMATSU
WA 300, WA 350, WA 500 PC 100 à PC 1250 One-piece tooth Ripper D60 to D375

MTG
Kingmet E Extra Kingmet H Heavy Kingmet U Universal





Ground engaging tools - Wear material

Edges and blades / Reinforcements



With our foundry partners, we also offer protections and reinforcements for buckets, blades and profiles and other wear parts.

Contact us for more information.

Wear buttons



WB 60 - d. 60 mm x 27 mm	10,81 €
WB 75 - d. 75 mm x 27 mm	13,91 €
WB 90 - d. 90 mm x 27 mm	18,55 €
WB 115 - d. 115 mm x 32 mm	40,39 €

Chocky bars



CB 25 - 240 mm x 25 mm x 23 mm	13,91 €
CB 40 - 240 mm x 40 mm x 23 mm	24,72 €
CB 50 - 240 mm x 50 mm x 23 mm	30,02 €
CB 65 - 240 mm x 65 mm x 23 mm	38,41 €
CB 100 - 240 mm x 100 mm x 23 mm	63,25 €

Bucket reinforcements



- Side protection
- Heel shrouds
- Lip protection
- Bolt-on half arrow protection
- Side cutters
- Side clips
- Complete bucket

Edge and blades



- Weld-on base blade
- Bolt-on blade
- Curved blade
- Cast blade
- Full range of end bits
- Complete scarificator shank
- Snowplow blade



- Reversible double bevel blade
- Half-arrow profile
- Serrated blade
- Preformed cast end bit
- Bolt-on half-arrow protection
- Complete ripper shank

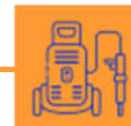



Ground engaging tools - Wear material

Custom parts



Our foundry partners can also produce custom parts, in high quality anti-abrasion steel (HARDOX in different indices) reinforced or not with chromium or tungsten carbide.

Tell us your project and we will come back to you with our best offer.

Custom parts
Cut abrasion-resistant steel sheets
Straight blade without hole
Abrasion-resistant flange
Delta blade
Blade with one line of holes
Blade with two lines of holes
Off-plan cutting blade
Machined part
Crusher hammer (recycling)
Sieves and perforated sheets

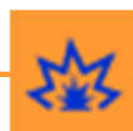
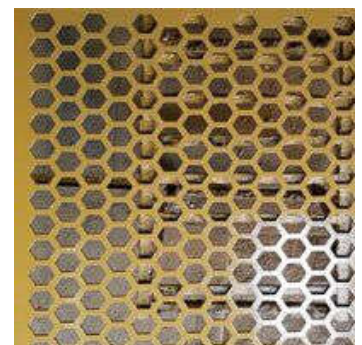
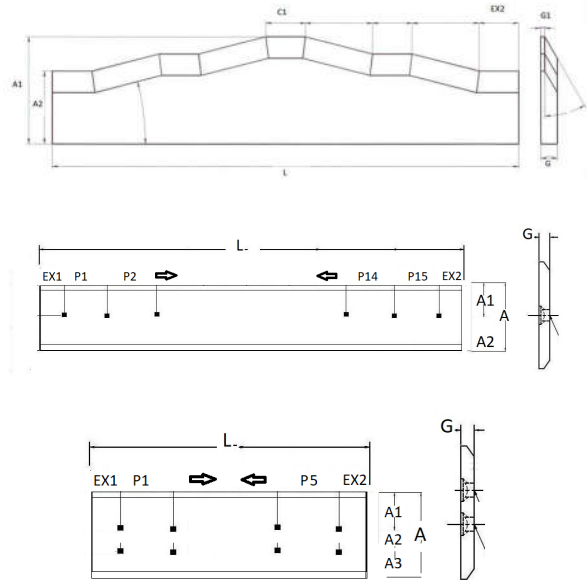



Ground engaging tools - Wear material

Points and picks



Points for hydraulic hammers:

We can offer you points for almost all hammers on the market: Caterpillar, Epiroc, Furukawa, Korota, Krupp, Montabert, Promove, Soosan, etc., in standard profile, x-shaped or with tungsten insertion.

Please tell us which hammer you are using and we will send you our best offer.

Standard		X-shaped	Tungsten insertion
 P Moll Point	 S Chisel	 XS	 HMP
 E Pyramidal Tool	 D Blunt tool	 XE	 HMXP
Conical Pyramidal	Chisel Blunt	Better dust evacuation on impact. Self-sharpening.	Tungsten alloy insert for hard and abrasive rock. Self-sharpening.

Picks for trenchers and road planers:

Our range of carbide picks and pick holders is suitable for most trenchers and road planers. We offer rods with diameters from 19.4mm to 38mm.

Please tell us the reference of your pick, and we will send you our best offer.

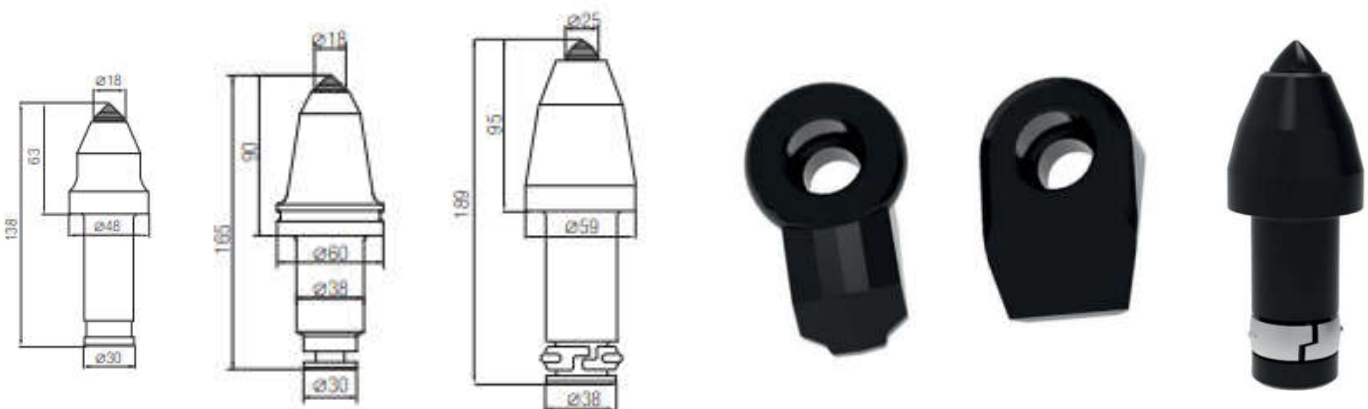



Powerwashers

Portable and mobile powerwashers

With our partner in Great Britain, we offer a wide range of industrial high-pressure washers. The range is available in portable, mobile and autonomous models.

Contact us for a complete description. The sale price is variable depending on the EUR/GBP exchange rate.

Model	Pressure	Volume	Hose		Weight
			In	Out	

Portable petrol

15KPL	103 bars	13,2 l/min	4,5 m	8 m	29,5 kg
15KPJ	103 bars	13,2 l/min	4,5 m	10 m	34 kg
20KPS	140 bars	13,2 l/min	4,5 m	10 m	34 kg

Mobile electric

10KEL	66 bars	13,2 l/min	4,5 m	8 m	58,5 kg
14KEL	100 bars	11,4 l/min	4,5 m	8 m	61,5 kg
14KE	100 bars	11,4 l/min	4,5 m	10 m	84 kg
20KE	150 bars	15 /min	4,5 m	15 m	84 kg
30KE-AS	207 bars	17 l/min	4,5 m	15 m	155,5 kg

Mobile petrol

20KPE	140 bars	13,2 l/min	4,5 m	10 m	67 kg
35KPE+ES	240 bars	15 l/min	4,5 m	15 m	115 kg
50KPE-VT	350 bars	16 l/min	4,5 m	30/50 m	175 kg
70KPE-VT	500 bars	16 l/min	4,5 m	20/50 m	180 kg

Mobile diesel

20KLN+ES	124 bars	13,2 l/min	4,5 m	10 m	85 kg
30KLN+ES	207 bars	15 l/min	4,5 m	15 m	86 kg

Note: ES = electric start





Powerwashers

Autonomous powerwashers



Autonomous powerwashers are equipped with a water tank, a 28 l detergent tank and a 15 l antifreeze tank, and powered by an on-board thermal engine.

They are available assembled on light trolley (water tank only), cold water trailer, silent trailer (78 dB at 1 meter) and hot water trailer.

Model	Pressure	Volume	Hose	Water tank	Weight
-------	----------	--------	------	------------	--------

Light trolley MBWT					
20KPS	140 bars	10 l/min	10 m	125 l	105 kg
20KDSB*	124 bars	10 l/min	10 m	125 l	105 kg
20KLN+ES*	124 bars	10 l/min	10 m	125 l	105 kg

Cold water trailer BBW					
20KPE	140 bars	13,2 l/min	10 m	940 l	500 kg
20KLN+ES*	124 bars	13,2 l/min	10 m	940 l	500 kg
30KLN+ES*	207 bars	15 l/min	15 m	940 l	500 kg
35KPE+ES	240 bars	15 /min	15 m	940 l	500 kg
50KPE-VT	350 bars	16 l/min	30 m	940 l	500 kg
70KPE-VT	500 bars	15 l/min	20 m	940 l	500 kg

Silent cold water trailer BBW					
30KDQ*	207 bars	15 l/min	30 m	940 l	678 kg
40KDQ*	280 bars	15 l/min	30 m	940 l	678 kg
50KDQ*	350 bars	13,5 l/min	30 m	940 l	678 kg

Hot water trailer HWBBW					
35KPE+ES	240 bars	13,2 l/min	15 m	700 l	800 kg
35KLN+ES*	220 bars	15 l/min	15 m	700 l	800 kg
50KPE-VT	345 bars	12,5 l/min	30 m	700 l	800 kg

Note: ES = electric start

* = diesel













Powerwashers

Accessories



The industrial powerwashers we offer can be equipped with accessories for specific use: surface or pipe cleaning, spraying to remove dust and odors, etc. The trailer chassis can also accommodate a 1000 l water tank, with or without pump.

Accessory	Application	Characteristics	
DT400	Spraying to remove dust and odors	Maximum pressure 250 bars. Adjustable angle 0 to 42° - Spraying 4 to 8 l/min. Weight 50 kg – On mobile chassis up to 75 m from the trailer powerwasher.	
DT400BM	Spraying to remove dust and odors	Maximum pressure 250 bars. Adjustable angle 0 to 42° - Spraying 4 to 8 l/min. Weight 50 kg – Assembled on trailer powerwasher rear hoop.	
MRJET25	Surface cleaning with rotating jet	Working width 520 mm. Use with 140 to 276 bar washer. Weight 12 kg – Two nozzles on rotating arm. Debris Retention Skirt.	
30KITLD	Pipe cleaning	30 m cleaning hose. Use with washer 140 to 276 bars. Weight 16 kg – Suitable for pipes 4" to 6" and up to 8' for short lengths.	
Gulper Kit	Pumping of charged water	5 m pumping hose. Pumping particles up to 25 mm up to 8 meters high. Weight 5 kg.	
ISKSB2300	Sandblasting	Suction of dry abrasive and mixing with water at high pressure. Abrasives: iron silicate, glass powder, calcium and sodium bicarbonate. Use with washer of 200 bars or more.	
Others	HotBox Mobile winder Rear winder Tank trailer Water tank Diesel tank Watering bar Protection Anti-theft security Lifting	120°C boiler for 103 to 207 bar washer. Naked or with 50 m or 75 m extension. On trailer rear hoop, up to 75 m. 1000 liters, with or without pump. 100 l mobile with Quick Connect coupling. Mobile 70 l hose 1.5 m with trigger nozzle. For trailer-mounted cleaner up to 345 bars. Engine and lance cover. Hitch lock, wheel clamp. Fork lifting points on trailer chassis.	 





Specific products

Self-drilling systems



We offer self-drilling systems for anchoring, nailing and micropiles, with diameters of 25 to 104 mm. Please contact us for complete details and sale prices.



Model	Diameter (mm)			Section (mm ²)	Load (kN)		Weight per m
	Ext.	Int.	Thread		Maximal	Nominal	
R 25-200	25	13,5	22,6	312	200	150	2,1
Anchor plates 150 and 200 mm – Bits d. 42 and 51 mm							
R 32-210	32	24	29,6	320	210	160	2,5
R 32-250	32	22	29,6	380	250	190	3,0
R 32-280	32	20	29,6	440	280	220	3,5
R 32-320	32	17	29,6	480	320	250	3,9
R 32-360	32	15	29,6	530	360	280	4,2
R 32-400	32	11	29,6	600	400	330	4,8
Anchor plates 150, 180 and 200 mm – Bits d. 45 to 90 mm (clay bit 150 mm)							
R 38-420	38	24	35,6	630	420	350	5,0
R 38-500	38	19	35,6	750	500	400	6,0
R 38-550	38	17	35,6	840	550	450	6,2
Anchor plates 200 and 300 mm – Bits d. 64 to 115 mm (clay bit 150 mm)							
R 51-550	51	38,0	48,6	840	550	450	6,5
R 51-660	51	34,5	48,6	990	660	540	7,7
R 51-800	51	30,0	48,6	1190	800	640	9,5
Anchor plates 150, 200, 250 and 300 mm – Bits d. 76 to 115 mm (clay bit 200 mm)							
T 76-1300	76	56,0	72,9	1950	1300	1000	15,4
T 76-1650	76	46,0	72,9	2400	1650	1200	18,9
T 76-1900	76	38,0	72,9	2930	1900	1500	23,0
Anchor plates 200, 250 and 350 mm – Bits d. 130 to 200 mm (clay bit 300 mm)							
T 103-2300	103	76,0	98,7	3450	2300	1900	27,0
Anchor plates 250 and 300 mm – Bits d. 175 mm (clay bit 225 and 280 mm)							
TG104-3550	104	57,0	98,7	5500	3550	2680	43,2
Anchor plates 250 and 300 mm – Clay bits 175 and 280 mm							

Rods 1 à 6 m – Bits available in version cross, button, asymmetrical and clay.





Specific products

Drill hammers and integral steels / Spare parts



Drill hammers :

We offer a range of drill hammers from 12 to 30 kg, drilling from 24 to 45 mm, with 19x108, 22x108 or 25x108 shanks, with or without water injection.

Please contact us for further information.



Integral drill steels :

Our integral drill steels are available with shank 22x108 and 25x108.

HEX 22x108 d/l in mm						HEX 25x108 d/l in mm		
42/600	39/1800	36/4000	34/800	33/1800	31/1600	42/800	39/3200	35/1600
40/800	38/2400	35/600	34/1200	32/1200	31/3200	41/1600	38/4000	34/2400
40/1200	38/2400	35/4800	33/800	32/2400	30/2000	40/2400	36/800	33/3200
39/1600	37/3200	34/400	33/1600	32/2400				

Spare parts :

Consult us with the O.E.M. (Original Equipment Manufacturer) reference for your Epiroc, Atlas Copco, Ingersoll Rand, Furukuwa or Sandvik top-hammer drill rigs. We can supply spare parts for most top-hammers on the market.





The publisher reserves the right to printing errors, changes in laws and regulations and possible product modifications..
2024 © MCEP DISTRIBUTION



MCEP

DISTRIBUTION

